

Technical Data



Contact Data

Type of Contact	Single Contact	
No. of Contacts	1C / 1A / 1B	
Rated Voltage / Max. Switching Voltage	VAC	250 / 440
Rated Current	A	8
Inrush Current	A	30
Rated Breaking Capacity (cos φ = 1)	VA	2000
Contact Material	AgCuNi; AgCdO; AgSnO; +Au	
Contact Resistance	mΩ	50

General Data

Mechanical Life	> Operations	50 x 10 ⁶
Electrical Life at Rated Voltage	> Operations	1,2 x 10 ⁵
Max. Switching Frequency	Operations / h	360
Operate Time / Release Time	approx. in ms	8 / 3
Bounce Time A / B	approx. in ms	0,5 / 5
Test Voltage Contact / Coil	≥ VAC _{eff}	5000
Test Voltage Contact Open	≥ VAC _{eff}	1000
Vibration Resistance A / B (10-55Hz)		10g / 1,5g
Creeping-/Leakage Distance	mm	14
Insulation IEC 60664	- Rated Voltage (VAC)	250
	- Degree of Pollutin	2
	- Excess Voltage Category	III
Insulation Group / Rated Voltage (VDE 0110b 2/79)		C / 250
Ambient Temperature	°C	- 40...+ 70
Temperature of Soldering Bath	°C / s	270 / 5
Approvals		VDE; UL; CUR
Weight	gr.	20

Coil at + 20°C

Rated Voltage	VDC	6...110
Power Consumption (DC - Coil)	approx. W	0,5 / 0,24

DC-Standard Coil (0,5 W)

U _N (V)	R Ω (Ohm)	U _{AN} (V)	U _{AB} (V)	I _N (mA)
6	70 ± 10%	≤ 4,5	≥ 0,3	85,70
12	270 ± 10%	≤ 9,0	≥ 0,6	44,40
24	1100 ± 10%	≤ 18,0	≥ 1,2	21,80
48	4400 ± 13%	≤ 36,0	≥ 2,4	10,90
60	6850 ± 15%	≤ 45,0	≥ 3,0	8,75
110	20000 ± 15%	≤ 82,5	≥ 5,5	5,50

Dimension Diagram

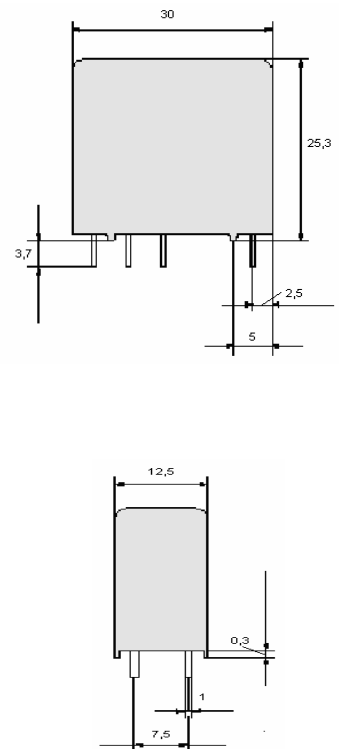

All measure in mm.

DC-Sensitive Coil (0,24 W)				
U_N (V)	$R \Omega$ (Ohm)	U_{AN} (V)	U_{AB} (V)	I_N (mA)
6	$160 \pm 10\%$	$\leq 4,5$	$\geq 0,3$	37,50
12	$720 \pm 10\%$	$\leq 9,0$	$\geq 0,6$	16,60
24	$2300 \pm 10\%$	$\leq 18,0$	$\geq 1,2$	10,40
48	$10000 \pm 15\%$	$\leq 36,0$	$\geq 2,4$	4,80
60	$15000 \pm 15\%$	$\leq 45,0$	$\geq 3,0$	4,00

Other coil tensions on request.

Schematic Diagram

Top View

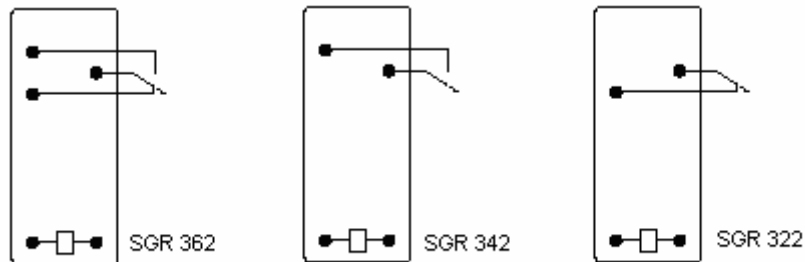

View of the solder side. All measure in mm.

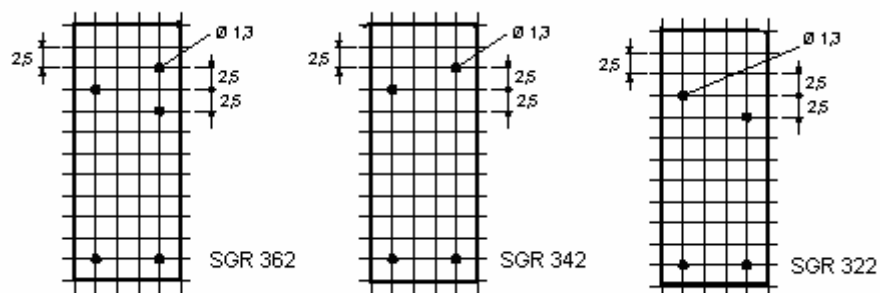

Order Type

SGR 362	E	012VDC	ACN
<p>Relay Type 362 = 1 Change-Over Contact 342 = 1 Normally Open Contact 322 = 1 Normally Closed Contact</p> <p>Construction Without = Washproof IP42 O = Dust-Proof IP54 V = Sealed IP67 E = Sensitive Coil 240mW T = Mechanical Actuation Button S = Special type after customer wish</p> <p>Coil Voltage 006VDC = 6VDC 110VDC = 110VDC</p> <p>Contact Material ACN = AgCuNi ACO = AgCdO ASO = AgSnO +Au =...+Hard Gold Plating</p>			

Electrical Specification

Excitation Voltage Range

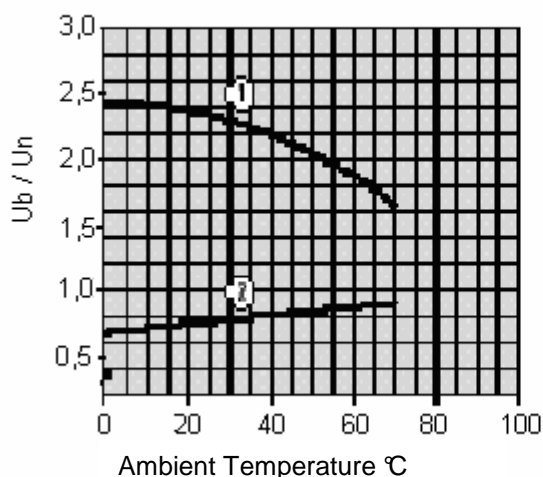

- Single relay on PCB, no heat accumulation on PCB by self heating from other components.
- Continuous duty 100%

- 1) Max. excitation voltage without contact load
- 2) Min. excitation voltage (guaranteed values) without previous operation